



design brief

COMMERCIAL KITCHEN VENTILATION DESIGN

Summary

At the outset of a new construction project, the building owner wants to limit design and installation costs. With budget constraints, the kitchen designer specifies ventilation hoods based on past experience that are adequate for capture and containment of cooking plumes without regard to energy efficiency. The mechanical engineer, in turn, strives for an effective but low cost HVAC (heating, ventilation, and air conditioning) system. Energy efficiency and energy costs are often of little concern to the design team. However, the energy efficiency of commercial kitchens is, in large part, directly related to the exhaust ventilation system.

The interaction between HVAC, makeup air, and exhaust systems is complex and until recently was not well documented. Recent research has demonstrated that hood type and local introduction of makeup air have a significant impact on exhaust and makeup air ventilation rates. These design elements are frequently not developed and specified by the same professional. Kitchen designers usually select the hoods while mechanical engineers design the HVAC and makeup air systems, often exchanging no more information than estimated exhaust rates. These design professionals may not fully understand the impact of their commercial kitchen ventilation (CKV) selections on energy consumption and occupant comfort.

These problems exist in part due to a lack of comprehensive design information for CKV systems. This design brief provides guidance to kitchen designers, mechanical engineers, and food service operators on commercial kitchen exhaust systems, and is intended to augment comprehensive design information published in the Kitchen Ventilation Chapter in the ASHRAE Handbook.¹

By properly designing the exhaust ventilation system for a new commercial restaurant, significant operational savings, energy efficiency, and environmental improvements can be achieved.

CONTENTS

Introduction	2
CKV Fundamentals	3
Hood Selection and Sizing	7
Makeup Air Optimization	13
Energy Considerations	20
Design Summary	20
CKV Example	24
Conclusion	25
For More Information	28
Notes	29

CKV DESIGN RESOURCES

Information in this Design Brief is based on the following two documents:

- Design Guide No. 1: Commercial Kitchen Ventilation – Exhaust Hood Selection & Sizing.²
- Design Guide No. 2: Improving Commercial Kitchen Ventilation System Performance, Optimizing Makeup Air.³

Additional information is provided in the Notes section for the two design guides and other CKV resources.

This brief focuses on methods of increasing the efficiency and effectiveness of the exhaust system while reducing the impact on the total building energy consumption and improving the kitchen environment. Key discussion areas include:

- The fundamentals of kitchen ventilation systems.
- The basics of hood selection and sizing.
- The influence and types of makeup air.
- Energy considerations for CKV systems.
- A summary of design strategies.
- A comparison of two CKV system designs.

Introduction

It has been shown that the HVAC load in a restaurant represents approximately 30 percent of its total energy consumption. Depending on the facility layout, the kitchen ventilation system can account for up to 50 percent of the HVAC load including fan energy, and may represent one of the larger energy-consuming end uses within a commercial food service facility. Unlike cooking appliances, which can be isolated for troubleshooting, the CKV system is affected by numerous components including the exhaust hood and the cooking appliances. To further complicate matters, the CKV system is also a subsystem of the overall building HVAC system.

As the plume rises from the cooking appliances by natural convection, it is captured by the exhaust hood and removed by the suction of the exhaust fan. Air in the proximity of the appliances and hood moves in to replace it. This replacement air, which originates as outside air, is referred to as makeup air (MUA). Fortunately, there is no “magic” to the relationship between an exhaust hood and its requirement for replacement air. The physics are simple: air that exits the building through exhaust hoods and fans for the CKV system must be replaced with outside air that enters the building, either intentionally or

otherwise. If replacement air doesn't come in, the "used" air does not go out the exhaust hood, and problems begin. Not only will the building pressure become too negative, the hood may not capture and contain cooking effluents due to reduced exhaust flow. An effective CKV system requires proper air balance. The designer, engineer, installer, and operator of the kitchen ventilation system must work together to ensure "air in" equals "air out" for an effective kitchen ventilation system.

CKV Ventilation Fundamentals

Cooking Appliances

Cooking appliances are categorized as light, medium, heavy, and extra-heavy duty depending on the strength of the thermal plume and the quantity of grease and smoke produced (see sidebar). The strength of the thermal plume is a major factor in determining the exhaust rate. By their nature, these thermal plumes are very turbulent and different cooking processes have different "surge" characteristics. For example, the plume from hamburger cooking is strongest when flipping the burgers. Ovens and pressure fryers may have very little plume until they are opened to remove food product. Open flame, non-thermostatically controlled appliances, such as underfired broilers and open top ranges, exhibit strong steady plumes. Thermostatically controlled appliances, such as griddles and fryers, have weaker plumes that fluctuate in sequence with thermostat cycling, particularly gas-fired equipment.

Building codes distinguish between cooking processes that create smoke and grease (e.g., frying, griddling, or charbroiling) and those that produce only heat and moisture (e.g., dishwashing and some baking and steaming operations). Cooking that produces smoke and grease requires liquid-tight construction with a built-in fire suppression system (Type I hood), while operations that produce only heat and moisture do not require liquid-tight construction or a fire suppression system (Type II hood).

APPLIANCE DUTY CLASSIFICATIONS

Light Duty

- Gas and electric ovens (including standard, bake, roasting, revolving, retherm, convection, combination convection/steamer, conveyor, deck or deck-style pizza, and pastry)
- Electric and gas steam-jacketed kettles
- Electric and gas compartment steamers (both pressure and atmospheric)
- Electric and gas cheesemelters
- Electric and gas rethermalizers

Medium Duty

- Electric discrete element ranges (with or without oven)
- Electric and gas hot-top ranges
- Electric and gas griddles
- Electric and gas double-sided griddles
- Electric and gas fryers (including open deep-fat fryers, donut fryers, kettle fryers, and pressure fryers)
- Electric and gas pasta cookers
- Electric and gas conveyor (pizza) ovens
- Electric and gas tilting skillets/braising pans
- Electric and gas rotisseries

Heavy Duty

- Electric and gas underfired broilers
- Electric and gas chain (conveyor) broilers
- Gas open-burner ranges (with or without oven)
- Electric and gas wok ranges
- Electric and gas overfired (upright) broilers
- Salamanders

Extra Heavy Duty

Appliances using solid fuel such as wood, charcoal, briquettes, and mesquite to provide all or part of the heat source for cooking.

Source: ASHRAE Standard 154⁴

Figure 1: Common Exhaust Hood Styles

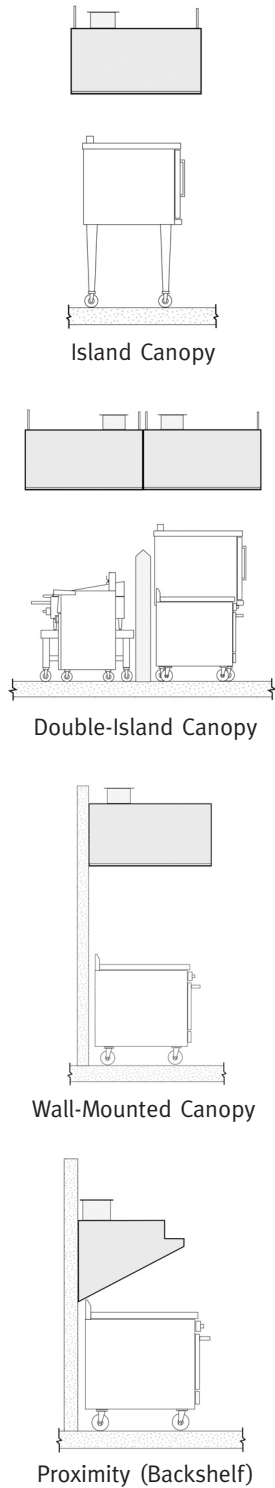

Source: Design Guide No. 2,
California Energy Commission

Exhaust Hoods

There is no piece of equipment that generates more controversy within the food service equipment supply and design community than the exhaust hood due to the variety of styles and makeup air combinations. The style and construction features of the exhaust hood affect the design exhaust rate. The capacity of an exhaust hood is measured typically in cubic feet per minute (cfm).

Wall-mounted canopy hoods, single- or double-island canopy hoods, and proximity hoods (which include backshelf, pass-over, or eyebrow) all have different capture areas and are mounted at different heights relative to the cooking equipment, as shown in **Figure 1**. Generally, for the identical thermal plume challenge, a single-island canopy hood requires more exhaust than a wall-mounted canopy hood, and a wall-mounted canopy hood requires more exhaust than a backshelf hood. The performance of a double-island canopy tends to emulate the performance of two back-to-back wall-canopy hoods, although the lack of a physical barrier between the two hood sections makes the configuration more susceptible to cross drafts.

Building codes provide basic construction and materials requirements for exhaust hoods, as well as prescriptive exhaust rates based on appliance duty and length of the hood (cfm per linear foot) or open face area of the hood (cfm per square foot). The codes also recognize exceptions for hoods that have been tested against a recognized standard, such as Underwriters Laboratories (UL) Standard 710.⁵ Part of the UL standard is a “cooking smoke and flare up” test. This test is essentially a cooking effluent capture and containment test where “no evidence of smoke or flame escaping outside the exhaust hood” must be observed. Hoods bearing a recognized laboratory mark are called *listed* hoods, while those constructed to the prescriptive requirements of the building code are called *unlisted* hoods. Generally, a listed hood can be operated at a lower exhaust rate than an unlisted hood of comparable style and size over the same cook line.

Although a well-engineered proximity hood can be applied with success at very low exhaust rates, if specified without performance data and in accordance with maximum height and setback permitted by code, this same type of hood may fail to effectively capture and contain the cooking effluent at higher exhaust rates. For example, a backshelf hood applied to handle 150 cfm per linear foot over medium duty equipment may fail to effectively capture and contain 300 cfm per linear foot or more. **Figure 2** illustrates a “good” and “bad” application of a proximity hood.

Laboratory testing of different combinations of appliances has demonstrated that minimum capture and containment rates vary due to appliance type and position under the hood. For instance, a heavy-duty appliance at the end of a hood is more prone to spillage than the same appliance located in the middle of the hood.

Exhaust Capacity

An exhaust fan in the ceiling could remove much of the heat produced by cooking equipment. However, adding smoke, volatile organic compounds, grease particles, and vapor from cooking creates a more complex mix, requiring a means to capture and contain the effluent to avoid health and fire hazards. Exhaust hoods serve that purpose.

The key issue for designers and engineers is knowing the appropriate exhaust rate, which is always dependent on the following factors:

- the type and use of the cooking equipment under the hood.
- the style and geometry of the hood itself.
- how the makeup air, which may or may not be conditioned, is introduced into the kitchen.

Figure 2: Examples of Proximity Hood Designs

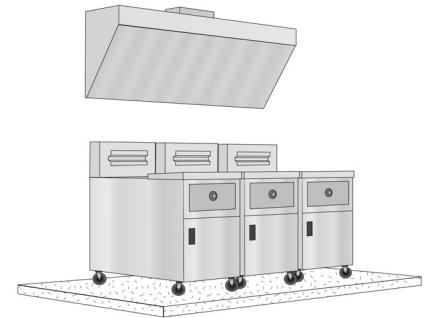

Ineffective Hood Design and Application

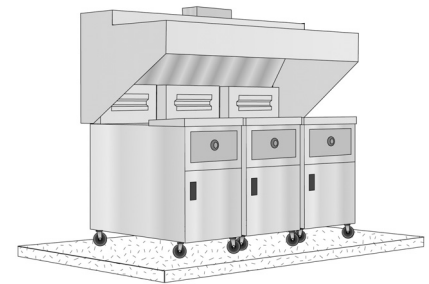

Effective Hood Design and Application

Source: Design Guide No. 1,
Southern California Edison

We have all experienced the “can’t-open-the-door” syndrome because the exhaust fan is sucking too hard on the inside of a restaurant creating negative building pressure. The mechanical design may call for 8,000 cfm of air to be exhausted through the hood. But if only 6,000 cfm of outdoor air is able to squeeze in through closed dampers on rooftop units and undesirable pathways in the building envelope, then only 6,000 cfm is available to be exhausted through the hood. The exhaust fan creates more suction or negative pressure in an unsuccessful attempt to pull more air through the hood.

Performance Testing

As defined in ASTM F-1704 Standard Test Method for the Performance of Commercial Kitchen Ventilation Systems⁶, “hood capture and containment is ability of the hood to capture and contain grease-laden cooking vapors, convective heat, and other products of cooking processes.” Hood capture refers to these products entering the hood reservoir from the area under the hood, while containment refers to these products staying in the hood reservoir and not spilling out into the adjacent space. The phrase “minimum capture and containment” is defined as “the conditions of hood operation in which minimum exhaust flow rates are just sufficient to capture and contain the products generated by the appliance in idle or heavy-load cooking conditions, and at any intermediate prescribed load condition.”

Performance testing in accordance with ASTM F-1704 occurs at various laboratories and may incorporate a schlieren flow-visualization system to verify capture and containment. This system is a major breakthrough for visualizing thermal and effluent plumes from cooking processes. “Schlieren” is derived from the German word for “smear.” A schlieren system presents an amplified optical image (see **Figure 3**) due to the different air densities, similar to the mirage effect that is seen over hot pavement.

Figure 3: Schlieren Images

These images show hood performance at different exhaust rates per linear foot (cfm/lf).

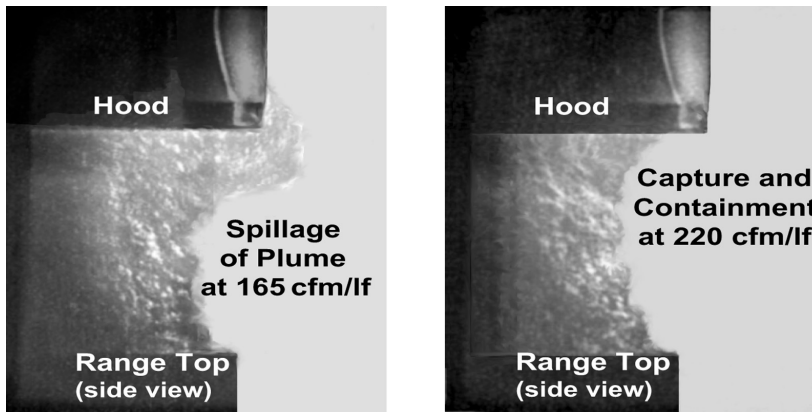

Source: Architectural Energy Corporation

Hood Selection and Sizing

Building Code Considerations

A good understanding of how building code requirements apply to kitchen design is essential for properly selecting and sizing exhaust hoods. Local or state building codes are usually based on one of the “model building codes” promulgated by national code organizations (see sidebar on page 9). The discussion of building codes will be limited in this design brief to requirements that affect design exhaust and makeup air rates, which are usually found in the mechanical code portion of the overall building code.

Historically, codes and test standards used temperature ratings for classifying cooking equipment. Although these temperature ratings roughly correlated with the ventilation requirement of the appliances, there were many gray areas. During development of ASHRAE Standard 154, it was recognized that plume strength, which takes into account plume volume and surge characteristics, as well as plume temperature, would be a better measure for rating appliances for application in building codes. The new measures, called duty ratings, were created for

the majority of commercial cooking appliances under Standard 154, and were recently adopted by the International Mechanical Code (IMC). The Kitchen Ventilation chapter of the ASHRAE Handbook applied the same concept to establish ranges of exhaust rates for listed hoods.

The IMC dictates exhaust rates based on hood type and appliance duty. **Table 1** states these exhaust rates in cfm per linear foot of hood, which in this case applies to the distance from edge to edge along the front face of the hood. The code requires that the exhaust rate for the highest duty rated appliance be applied to the entire hood. The Uniform Mechanical Code (UMC), used in many California jurisdictions, requires calculating exhaust rates based on the square footage of the capture area, describing capture area as the open area defined by the lower edges of the hood. The UMC uses temperature classifications for appliances, as described above. Both the IMC and the UMC require a minimum six-inch hood overhang, on the front and sides, for canopy-style hoods.

The prescriptive mechanical code exhaust rate requirements must be conservative because the AHJ (authority having jurisdiction) has no control over the design of an exhaust hood or the positioning and diversity of appliances placed beneath that hood. However, in cases where the CKV system design and

Table 1. Unlisted Hood Exhaust Flow Rates

IMC Minimum Exhaust Flow Rate for Unlisted Hoods (cfm per linear foot of hood)				
Type of Hood	Light Duty Equipment	Medium Duty Equipment	Heavy Duty Equipment	Extra-Heavy Duty Equipment
Wall-mounted Canopy	200	300	400	550
Single Island Canopy	400	500	600	700
Double Island Canopy	250	300	400	550
Eye Brow	250	250	not allowed	not allowed
Backshelf/Passover	250	300	400	not allowed

Source: ASHRAE Handbook

appliance configuration have been optimized, the code-specified exhaust rate may be significantly greater than what is required for effective capture and containment of the cooking plume. The code-based safety factor may be necessary for non-engineered systems, but can increase fan energy as well as place an energy cost burden on the CKV system through its demand for more heated and cooled makeup air.

When the energy crisis of the 1970s occurred, kitchen ventilation systems became an obvious target. The industry responded with two methods of reducing the amount of replacement air that had to be cooled or heated: (1) short-circuit hoods, and (2) listed hoods.

The first method, called “internal compensation,” was to introduce the makeup air directly into the hood reservoir. This is more commonly known as short-circuit makeup air. Although short-circuit hoods have been installed and operated with as much as 80 percent of replacement air being introduced internally, field and laboratory investigations have shown that these hoods fail to capture and contain effluent adequately. Generally, not more than 15 percent of the replacement air can be introduced internally without interfering with proper capture and containment.

The second industry strategy was to test hoods under laboratory conditions according to the test protocol specified by UL Standard 710 - Standard for Safety for Exhaust Hoods for Commercial Cooking Equipment, which covers materials and construction of exhaust hoods as well as capture and containment performance. The capture and containment performance is based on testing a single appliance under a representative hood at up to three cooking temperature-operating set points (400°F, 600°F, or 700°F). The UL listing reports the minimum performance rate determined under this laboratory test. Designers should apply a safety factor to address dynamic conditions encountered in real kitchens.

MODEL BUILDING CODES

Historically, the United States had three organizations that sponsored model building codes, which were then adopted by local jurisdictions. These organizations sponsored development of standardized building codes, usually called “model building codes,” to assure better code uniformity within the three regions in which they evolved.

In the northeast U.S., the Building Officials Council Association sponsored the National Building Code. In the southeast U.S., the Southern Building Code Council International sponsored the Standard Building Code. In the western U.S., the International Council of Building Code Officials sponsored the Uniform Building Code (UBC). California jurisdictions adopted the UBC, including the Uniform Mechanical Code (UMC).

In 1994, these organizations formed the International Code Council to unify their codes. In 2000, the first full edition of the International Building Code (IBC) was published.

In 2000, the National Fire Protection Association (NFPA) announced that it would sponsor a complete building code that would compete with the IMC. In 2002, NFPA published its first edition.

Mechanical code requirements for kitchen ventilation are similar among these model codes.

Although manufacturers do not publish safety factors to be applied to their minimum listed cfm, they will typically recommend increasing the exhaust rate by five to 25 percent over the minimum listing.

The ASTM Standard F-1704 covers exhaust hood capture and containment performance as well as heat gain from hooded appliances. The current version does not address dynamic conditions, but there are amendments under consideration to add a dynamic test that would help quantify a safety factor. The capture and containment test in UL 710 and ASTM F-1704 are similar.

While the exhaust rates shown in **Table 1** are minimum mandatory rates for unlisted hoods, the rates in **Table 2** reflect the typical range in design exhaust rates for listed hoods. The values in this table may be useful for estimating the cfm advantage offered by listed hoods over unlisted hoods for a given project. However, in the final stage of design, exhaust rates may be adjusted to account for the following.

- Diversity of operations (how many of the appliances will be used at the same time).
- Position under the hood (appliances with strong thermal plumes, located at the end of a hood, tend to spill effluent more easily than the same appliance located in the middle of the hood).
- Hood overhang (in combination with appliance pushback). Positioning a wall-mounted canopy hood over an appliance line with an 18-inch overhang can dramatically reduce the required ventilation rate when compared to the minimum overhang requirement of six inches. Some manufacturers list their hoods for a minimum 12-inch overhang, providing an immediate advantage over unlisted hoods.
- Appliance operating temperature (e.g. a griddle used exclusively by a chain restaurant at 325°F vs. 400°F surface temperature) or other specifics of appliance design (e.g. 18-inch vs. 24-inch deep griddle surface).

- Operating experience of a chain restaurant may be factored into the equation. For example, the CKV system design exhaust rate (for the next new restaurant) may be increased or decreased based on real-world assessments of the CKV system in recently constructed facilities.

Table 2. Typical Exhaust Rates for Listed Hoods

Type of Hood	Minimum Exhaust Flow Rates for Listed Hoods (cfm per linear foot of hood)			
	Light Duty Equipment	Medium Duty Equipment	Heavy Duty Equipment	Extra-Heavy Duty Equipment
Wall-mounted Canopy	150-200	200-300	200-400	350+
Single Island Canopy	250-300	300-400	300-600	550+
Double Island Canopy	150-200	200-300	250-400	500+
Eye Brow	150-250	150-250	not allowed	not allowed
Backshelf/Passover	100-200	200-300	300-400	not recommended

Source: ASHRAE Handbook

Hood Geometry

Interior angles close to, or at, the capture edge of the hood improve capture and containment performance, allowing reduced exhaust by directing effluent back towards the filters. Hoods designed with these better geometric features require as much as 20 percent less exhaust rate compared to hoods identical in size and shape without these features. Capture and containment performance may also be enhanced with active low-flow, high-velocity air jets along the perimeter of the hood.

Cross Drafts

Cross drafts can have a detrimental effect on all hood and appliance combinations. Cross drafts affect island canopy hoods more than wall-mounted canopy hoods. For example, pedestal fans used by staff for additional cooling can severely degrade hood performance and make capture impossible. Cross drafts can also develop when the makeup air system is not working correctly, causing air to be pulled from open drive-through or pass-through windows or doors.

Side Panels and Overhang

Side or end panels permit a reduced exhaust rate in most cases, as all of the replacement air is drawn across the front of the equipment, which improves containment of the effluent plume generated by the hot equipment. Panels are a relatively inexpensive way to improve capture and containment, and reduce the total exhaust rate. End panels also mitigate the negative effect that cross drafts can have on hood performance. It is important to know that partial side panels can provide almost the same benefit as full panels. Also, end panels can improve the performance of a double-island or single-island canopy hood, although the panels tend to alter the definition of those hoods as an island canopy.

Safety Factors in Exhaust Rates

Safety factors are typically applied to the design exhaust rate to compensate for the uncertainty of the design process and the effect that undesired air movement within the kitchen has on hood performance. Better designs allow reduced exhaust rates and minimized energy costs while maintaining a margin of safety with respect to capture and containment.

Idle Conditions

Appliances idle much of the day. Using two-speed or variable exhaust flow rates to allow reductions in exhaust and makeup while appliances are idling help minimize operating costs. NFPA 96 - Standard for Ventilation Control and Fire Protection of Commercial Cooking Operations⁷ was recently amended to allow minimum exhaust duct velocity as low as 500 fpm (feet per minute) at the exhaust collar and ductwork. Typical design values of 1,500 to 1,800 fpm at the exhaust collar are still recommended for normal cooking conditions. This code change will facilitate the application of demand ventilation controls.

Makeup Air Optimization

MUA Influence

The design and engineering team should consider and plan for how the makeup air is best introduced into the building. The layout of the HVAC and MUA supply air outlets or diffusers can affect hood performance and can disrupt thermal plumes and hinder capture and containment.

A restaurant operator who thinks that not installing a dedicated makeup air supply will save money in both first cost and operating cost is short sighted. By design, it may be acceptable to have all the makeup air provided through rooftop HVAC units. This strategy has been adopted successfully by several leading quick-service restaurant chains. However, in full-service and institutional kitchens with larger exhaust requirements, it may not be practical or energy efficient to supply 100 percent of the replacement air through the building HVAC system.

The solution may be to specify an independent MUA supply. However, the challenge of a dedicated MUA supply is how to introduce air into the kitchen without disrupting the ability of the hood to capture and causing discomfort for the kitchen staff. Most kitchens are not extremely large, and dumping 7,000 cfm of replacement air, for example, in front of a cook line does not go as smoothly in practice as it looks on paper. Not only can makeup air velocities impact the ability of the hood to capture and contain cooking effluent, locally supplied makeup air that is too cold or too hot can create an uncomfortable working environment and increase significantly the energy consumption of the HVAC system.

Types of MUA Supply

Since air removed from the kitchen through the exhaust hood must be replaced with an equal volume of outside replacement air, one or more of the following pathways are typically used.

Figure 4: Types of MUA Supply Integrated With the Hood Plenum

The following MUA types are shown from top to bottom: short circuit, air curtain supply, front face supply, perforated perimeter supply, and backwall supply.

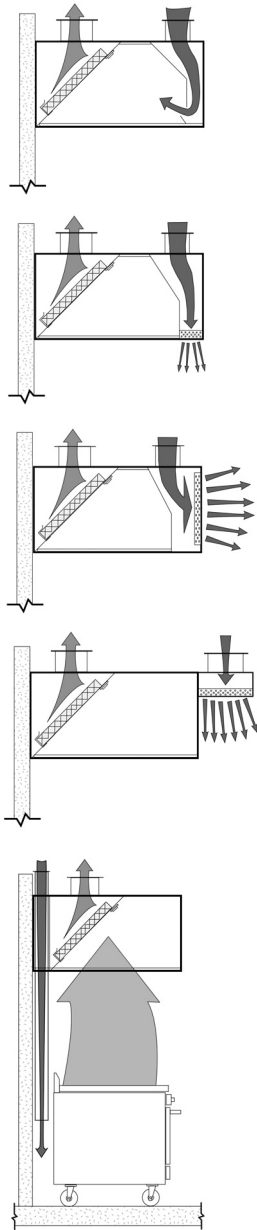

Source: Design Guide No. 2, California Energy Commission

- Transfer air – for instance, air from the dining room.
- Displacement diffusers, which may be floor- or wall-mounted.
- Ceiling diffusers with louvers that are two-way, three-way, or four-way.
- Slot diffusers located in the ceiling.
- Ceiling diffusers with a perforated face.
- Integrated hood plenum including (see **Figure 4**):
 1. Short circuit or internal supply.
 2. Air curtain supply.
 3. Front face supply.
 4. Perforated perimeter supply.
 5. Backwall or rear supply.
 6. Combinations of the above.

MUA Strategies

Makeup air that is supplied through displacement ventilation diffusers remote from the hood, perforated diffusers located in the ceiling as far as possible from the hood, or as transfer air from the dining room generally works well if air velocities approaching the hood are less than 75 fpm. Makeup air introduced in close proximity to an exhaust hood has the potential, however, to interfere with the hood's ability to capture and contain. The chances of makeup air affecting hood performance increases as the percentage of the locally supplied MUA (relative to the total exhaust) is increased. In fact, the rule-of-thumb that uses 80 percent for sizing airflow through a MUA unit can be a recipe for trouble, particularly if the engineer or designer over specified the exhaust flow rate from the start.

Temperature of the locally supplied makeup air can also impact hood performance as air density or buoyancy impacts the dynamics of air movement around the hood. Generally, hotter MUA temperatures (e.g., 90°F) will affect hood performance more adversely than cooler air (e.g., 75°F). In most temperate climates, such as many areas in California, evaporative cooling is an effective method of maintaining MUA temperatures within a range that is comfortable for kitchen staff and does not hamper hood performance. However, the maintenance requirements of evaporative coolers must be factored into the equation.

The primary recommendation for minimizing the impact that locally supplied MUA will have on hood performance is to minimize the velocity (fpm) of the makeup air as it is introduced near the hood. This can be accomplished by minimizing the volume (cfm) of makeup air through any one pathway, by maximizing the area of the grilles or diffusers through which the MUA is supplied, or by using a combination of pathways.

The first step in reducing the MUA requirement is to minimize the design exhaust rate. This can be accomplished by prudent selection and application of UL Listed hoods and taking advantage of the exhaust flow recommendations from hood suppliers for the cookline under consideration. Exhaust hood manufacturers' sales and engineering departments have extensive experience that CKV consultants can tap to help minimize design exhaust rates.

The second step in reducing MUA flow is to take credit for outside air that must be supplied by the HVAC system to meet code requirements for ventilating the dining room. Depending on the architectural layout between the kitchen and the dining room, it may be practical to transfer most of this air from the dining room to the kitchen. For example, if 2,400 cfm of outdoor air that is being supplied to a 160-seat

dining room can be transferred to the kitchen, the local makeup air requirement can be reduced accordingly. Although this may contradict past practice, research has shown it to be a more effective strategy. Not only will hood performance be superior, the kitchen environment will benefit from the cooling contribution of the “recycled” dining room air.

The third step in reducing MUA flow is to select a configuration for introducing this local makeup air into the kitchen that complements the style and size of hood. Rather than supplying 80 to 90 percent of the exhaust rate through one makeup air strategy, designers should make an effort to keep this ratio below 60 percent. Obviously, the other 40 percent of the replacement air must be derived from another source such as transfer air, another local strategy, or HVAC supply. If transfer air is not an option, consider a combination of makeup air strategies (e.g., backwall supply and perforated ceiling diffusers). The pros and cons of the different configurations are discussed below. Minimizing MUA discharge velocity is key to avoiding detrimental impacts on hood capture and containment, and a frequent theme for the various configurations.

Short-Circuit Supply (Internal Makeup Air)

The application of short-circuit makeup air hoods is a controversial topic. These internal makeup air hoods were developed as a strategy to reduce the amount of conditioned air required by an exhaust system. By introducing a portion of the required makeup air in an untempered condition directly into the exhaust hood reservoir, the net amount of conditioned air exhausted from the kitchen is reduced. However, research has shown that in the cases tested, internal MUA cannot be introduced at a rate that is more than 15 percent of the threshold capture and containment exhaust rate without causing spillage. This sometimes contradicts what is shown on

the air balance schedule or in marketing literature. When short-circuit hoods are operated at higher percentages of internal MUA, they fail to capture and contain the cooking effluent, often spilling at the back of the hood (although front spillage has also been observed). Dilution of the cooking effluent with the internal MUA makes it hard to visualize spillage, but a degraded kitchen environment is confirmation that hood performance has been compromised. If the design exhaust rate is significantly higher than the threshold for capture and containment (i.e., includes a large safety factor), the percentage of short-circuit air can be increased accordingly, creating a condition of apparent benefit.

In most cases, short-circuit hoods are simply not recommended. This recommendation is endorsed by leading hood manufacturers, even though they may still include short-circuit hoods in their catalogue.

Air Curtain Supply

Introducing MUA through an air curtain is a risky design option and most hood manufacturers recommend limiting the percentage of MUA supplied through an air curtain to less than 20 percent of the hood's exhaust flow.

An air curtain by itself, or in combination with another pathway, is not recommended unless velocities are kept to a minimum and the designer has access to performance data on the actual air curtain configuration being specified. It is too easy for the as-installed system to oversupply, creating higher discharge velocities that cause cooking effluent to spill into the kitchen.

Front Face Supply

Supplying air through the front face of the hood is a configuration that has been recommended by many hood manufacturers. However, a front face discharge, with louvers or perforated face, can perform poorly if its design does not

consider discharge air velocity and direction. Not all face discharge systems share the same design; internal baffling and a double layer of perforated plates improve the uniformity of flow. Face discharge velocities should not exceed 150 fpm and should exit the front face in a horizontal direction. Greater distance between the lower capture edge of the hood and the bottom of the face discharge area may decrease the tendency of the MUA supply to interfere with hood capture and containment. A poorly designed face supply can negatively affect hood capture in the same fashion as an air curtain or four-way diffuser.

Backwall Supply

Lab testing has shown that the backwall supply can be an effective strategy for introducing MUA. However, the discharge area of the backwall supply should be at least 12 inches below the cooking surfaces of the appliances to prevent the relative high velocity introduction of MUA from interfering with gas burners and pilot lights. As with other local MUA strategies, the quantity of air introduced through the backwall supply should be no more than 60 percent of the hood's exhaust flow. Hoods with a deeper plenum or increased diffuser area have lower discharge velocities, allowing higher supply airflows. The back supply plenum may offer the advantage of meeting a "clearance to combustibles" code requirement. It may also be an option to convert a single island canopy into a more functional wall-mounted canopy without actually constructing the wall as utility distribution can be incorporated within the plenum. If the rear supply utilizes perforated diffusers, it is important that cleanout access be provided as with any supply diffuser.

Perforated Perimeter Supply

Perforated supply plenums with a perforated face diffuser are similar to a front face supply, but the air is directed downward toward the hood capture area. This may be advantageous under

some conditions, since the air is directed downward into the hood capture zone. Face discharge velocities should not exceed 150 fpm from any section of the diffuser, and the distance to the lower edge of the hood should be no less than 18 inches or the system begins to act like an air curtain. Widening the plenum will lower the discharge velocity for a given flow of MUA and reduce the chance of the supply air affecting capture and containment. If the perforated supply plenum is extended along the sides of the hood as well as the front, the increased area will permit proportionally more MUA to be supplied.

Four-Way Ceiling Diffusers

Four-way diffusers located close to kitchen exhaust hoods can have a detrimental effect on hood performance, particularly when the flow through the diffuser approaches its design limit. Air from a diffuser within the vicinity of the hood should not be directed toward the hood. Discharge velocity at the diffuser face should be set at a design value such that the terminal velocity does not exceed 50 fpm at the edge of the hood capture area. It is recommended that only perforated plate ceiling diffusers be used in the vicinity of the hood, and it is suggested to reduce air velocities from the diffusers at a given supply rate. The more diffusers used, the better the system will perform.

Displacement Diffusers

Supplying makeup air through displacement diffusers at a reasonable distance away from the hood is an effective strategy for introducing replacement air. It is analogous to low-velocity transfer air from the dining room. However, the diffusers require floor or wall space, which is usually at a premium in the commercial kitchen. A couple of remote displacement diffusers, built into a corner, could help diversify the introduction of makeup air into the kitchen when transfer air is not a viable option.

Energy Considerations

The exhaust ventilation system can be a major energy user in a commercial kitchen—but it doesn't need to be in temperate climates such as California. Some facilities may cool makeup air to improve kitchen comfort. Combined heating and cooling costs for replacement air range from \$0.00 to \$0.60 per cfm in California climates, assuming 16 hours per day for 365 days per year. Mild climates, such as San Diego, may require no heating or cooling. Evaporative cooling can be also very effective in most California climate zones.

The magnitude of the energy consumption and cost of a CKV system is due to key factors such as geographic location, operating hours of the system, static pressure and fan efficiencies, makeup air heating setpoint, and makeup air cooling setpoint and level of dehumidification. Other factors affecting the energy cost include efficiency of lighting, heating and cooling systems, level of interaction with kitchen HVAC system, appliances under the hood and associated heat gain to space, and applied utility rates. These end uses offer additional energy efficiency opportunities. A chart detailing the typical energy consuming systems in commercial kitchens is shown in **Figure 5**.

Rule-of-thumb figures such as dollars per cfm may be useful to estimate energy consumption and cost, but designers can calculate the costs of a specific kitchen design and operation using the Outdoor Airload Calculator (OAC) software.⁸ The OAC software is the best tool for quickly estimating the energy use for different CKV design and operating strategies. **Figure 6** illustrates the OAC program interface and output.

Design Summary

Successfully applying the fundamentals of kitchen ventilation during the design process requires a good understanding of the owner's menu and appliance preferences, the project's budget, and, as mentioned, the local building code

Figure 5: End-Use Pie Chart of Commercial Kitchens

The CKV and HVAC systems account for approximately 28 percent of energy use in commercial kitchens. Other major energy consuming elements include water heating, cooking, refrigeration, and lighting. The chart shown below details the main electric and gas consuming systems.

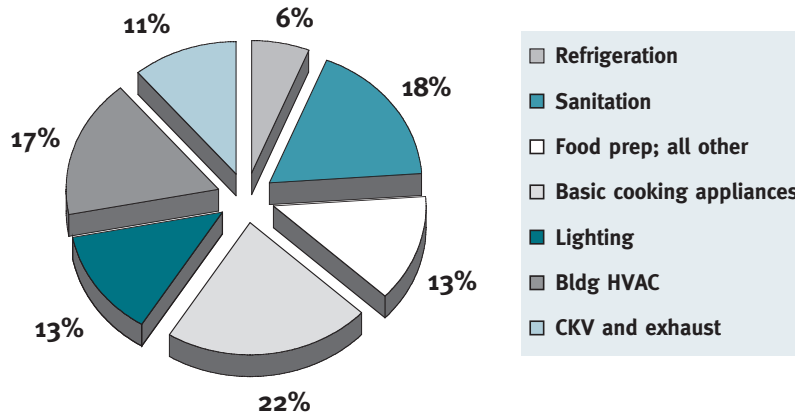

Source: Food Service Technology Center

requirements. Information about the owner's kitchen equipment and ventilation requirements may evolve over the course of the design phase. Data needed by other members of the design team may require early estimates of certain parameters (e.g., the amount of exhaust and makeup air, motor horsepower, water supply and wastewater flow rates). As more decisions are made, new information may allow or require refinements to the design that affect exhaust and makeup air requirements. The fundamental steps to an effective CKV system design are:

- Establish position and duty classifications of appliances.
- Determine (or negotiate with foodservice consultant) the preferred appliance layout for optimum exhaust ventilation.
- Select hood type, style, and features.
- Size exhaust airflow rate.
- Select makeup air strategy, and size airflow and layout diffusers.

Figure 6: Outdoor Airload Calculator Screen Shot

PG&E Food Service Technology Center - Kitchen Monitor Version 1.3

File Edit Options Details Calculate

Outdoor Airload Calculator

State Selection: California
City Selection: SACRAMENTO
Operating Hours: From: 8:00 AM Until: 12:00 PM
Air Setpoints: Heat Setpt: 65 F Cool Setpt: 76 F Outdoor Air Flow: 8000 cfm

Status Messages:

Text Results Table Results

```

Location:                SACRAMENTO, California
Operating Hours:        8:00 o'clock until 0:00 o'clock Hours of Operation: 16
Makeup Air Flow:       8000 cfm Thermostat Setpoints: Heating = 65 F, Cooling = 76 F

The Heating Design Load is: 288.5 kBtu/h. The Cooling Design Load is: 218.7 kBtu/h.
Calculated Monthly loads:
Month                   Heating Load           Cooling Load
January      :           79,397 kBtu                0 kBtu
February    :           49,907 kBtu                0 kBtu
March       :           52,075 kBtu                0 kBtu
April       :           28,455 kBtu                397 kBtu
May        :           10,418 kBtu                6,682 kBtu
June       :            4,927 kBtu               13,922 kBtu
July       :            963 kBtu                 24,612 kBtu
August    :            2,123 kBtu                24,391 kBtu
September :            2,676 kBtu                12,774 kBtu
October   :            9,700 kBtu                 2,273 kBtu
November  :           43,404 kBtu                 0 kBtu
December  :           80,857 kBtu                 0 kBtu
Total_Year :          364,901 kBtu                85,051 kBtu

FAN ENERGY CALCULATIONS:
Total Static Pressure:   Supply           Exhaust
                        0.5 inW           1.0 inW
Fan Type:                Backward_Inclined Backward_Inclined
Fan Efficiency:          78.0 %           78.0 %
Motor Efficiency:        83.0 %           84.0 %
Motor Output Power:      0.811 HP           1.623 HP
Motor Rated Input:       0.729 kW           1.441 kW
Motor Energy Consumption: 4257 kWh           8413 kWh
    
```

Source: Architectural Energy Corporation

As discussed in the makeup air section, the strategy used to introduce replacement air can significantly impact hood performance and is a key factor in the design of kitchen ventilation systems. Makeup air introduced close to the hood's capture zone may create local air velocities and turbulence that result in periodic or sustained failures in thermal plume capture and containment.

In summary, the following design strategies can improve the performance and energy efficiency of commercial kitchen ventilation systems:

- Group appliances according to effluent production and associated ventilation requirements. Specify different ventilation rates for hoods or hood sections over the different duty classification of appliances. Where practical, place heavy-duty appliances such as charbroilers in the center of a hood section, rather than at the end.
- Use UL Listed proximity type hoods where applicable.
- Hood construction details (such as interior angles and flanges along the edge) or high-velocity jets can promote capture and containment at lower exhaust rates.
- Install side and/or back panels on canopy hoods to increase effectiveness and reduce heat gain.
- Maximize transfer air/minimize direct makeup air. Integrate the kitchen ventilation with the building HVAC system (i.e., use dining room outdoor air as makeup air for the hood).
- Do not use short-circuit hoods. Use caution with air-curtain designs.
- Avoid four-way or slot ceiling diffusers in the kitchen, especially near hoods.

- Diversify makeup air pathways using a combination of backwall supply, perforated perimeter supply, face supply, displacement diffusers, etc.
- Minimize MUA velocity near the hood; it should be less than 75 fpm.
- Use direct-fired MUA heating if heating is necessary. In most temperate climates, including much of California, design for no MUA heating.
- Consider evaporative MUA cooling in dry climates such as California.
- Consider variable or two-speed exhaust fan control for operations with a high diversity of appliances or with a set schedule of use.
- Include air balance schedule in design drawings to avoid over- or under-supply of MUA.
- Require building air balancing and system commissioning as part of the construction requirements.

CKV Example

To illustrate the considerations of integrating fundamental ventilation principles into an actual design, an example utilizing a basic restaurant layout is provided on pages 26 and 27. The example compares a conventional design using an off the shelf approach with an engineered approach, which provides a more optimized design. The engineered approach will improve the comfort level of the kitchen staff and save approximately two-thirds of the energy cost.

Conclusion

In this design brief, the fundamentals of hood sizing and selection, and the influences of makeup air have been discussed. Design issues have been identified and strategies suggested. By properly designing exhaust ventilation systems for new commercial restaurants, significant operational savings, energy efficiency, and environmental improvements can be achieved.

Challenge: Improve Hood Capture and Containment and Reduce Ventilation Energy

Off-the-Shelf Approach

An unlisted wall mounted canopy hood (20-ft by 4-ft) without side panels: total exhaust 8,000 cfm. Four-way ceiling diffusers supplying air from the kitchen HVAC and MUA unit are located about two feet from front and sides of the hood.

Makeup Air Sources:

- 1000 cfm from dining and kitchen HVAC unit (25 ton refrigeration capacity).
- 7000 cfm from independent MUA (heating only, ductstat set to 65°F) supplied through four-way ceiling diffusers.

Annual CKV energy cost (including MUA conditioning and exhaust and MUA fan energy) estimated at \$6000 (\$0.75 per cfm) for Sacramento, California location (using \$0.15/kWh and \$0.60 per therm).

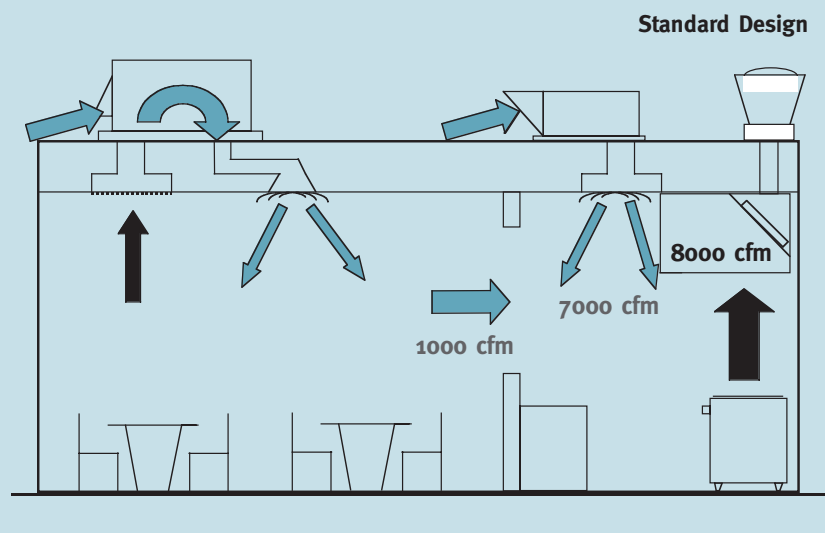

Engineered Approach

A listed hood (20-ft by 4.5-ft each) with partial side panels for a total exhaust of 6,000 cfm. Maximized use of transfer air. Perforated ceiling diffusers away from the hoods for the MUA supply.

Makeup Air Sources:

- 1500 cfm from kitchen HVAC unit (15 ton, 7000 cfm total supply).
- 1500 cfm from dining HVAC unit (10 ton, 5000 cfm total supply).
- 3000 cfm from independent MUA (no heating with evaporative cooling).

Annual CKV energy cost estimated at \$2000 (\$0.25 per cfm) for Sacramento, California location, for a \$4000 saving over standard design.

Note: Hoods designed to meet exhaust levels required by building codes, but not listed by a certified laboratory in accordance with a recognized test standard. For identical cooking equipment, unlisted hoods typically require higher exhaust flows than listed hoods.

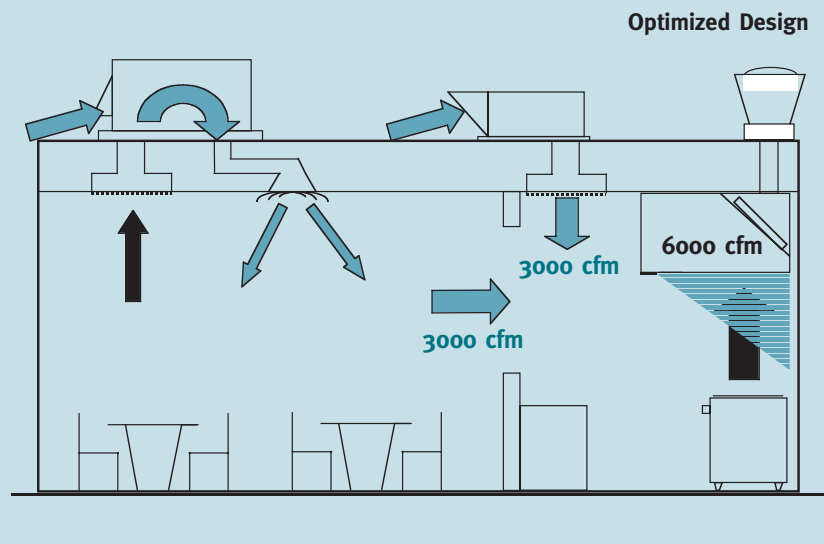

Energy costs for both approaches based on December 2003 energy rates.

FOR MORE INFORMATION

ASHRAE

American Society of Heating, Refrigerating & Air Conditioning Engineers
1791 Tullie Circle, N.E.
Atlanta, GA 30329
Phone: (404) 636-8400
Fax: (404) 321-5478
www.ashrae.org

CKV Laboratory

The CKV laboratory is funded by the FSTC and operated by Architectural Energy Corporation.
955 North Lively Blvd
Wood Dale, IL 60191
Phone: (630) 860-1439
Fax: (630) 860-1442
www.archenergy.com/services/food/ckvfacility

Energy Design Resources

Energy Design Resources provides resources and information on a number of energy efficiency and integrated energy design topics.
www.energydesignresources.com

Food Service Technology Center

The Food Service Technology Center is funded by Pacific Gas & Electric Company and operated by Fisher Nickel inc.
12949 Alcosta Blvd. Suite 101
San Ramon, CA 94583
Phone: (925) 866-2844
Fax: (925) 866-2864
www.fishnick.com/fni.html

Notes

- 1 2003 ASHRAE Handbook on HVAC Applications, Chapter 31, Kitchen Ventilation.
- 2 Design Guide No. 1: Commercial Kitchen Ventilation – Exhaust Hood Selection and Sizing. This design guide was prepared as a result of work sponsored by Southern California Edison. The document is available for download at www.fishnick.com/publications.
- 3 Design Guide No. 2: Improving Commercial Kitchen Ventilation System Performance, Optimizing Makeup Air. This design guide was prepared as a result of work sponsored by the California Energy Commission. The document is available for download from the following locations: www.energy.ca.gov/reports/reports_500.html and www.fishnick.com/publications/reports/special/CommercialKitchenVentilationDesignGuide.pdf.
- 4 ASHRAE Standard 154-2003, Ventilation for Commercial Cooking Operations (ANSI approved). Information on the standard is available at www.ashrae.org.
- 5 2000 Underwriters Laboratories, Standard 710, Standard for Safety for Exhaust Hoods for Commercial Cooking Equipment. Information is available at the following web site: ulstandardsinfontet.ul.com/scopes/0710.html.
- 6 ASTM International, F-1704-99 Standard Test Method for Performance of Commercial Kitchen Ventilation Systems. Information is available at the following web site: www.astm.org.
- 7 2001 NFPA 96 - Standard for Ventilation Control and Fire Protection of Commercial Cooking Operations. Information is available at the following web site: www.nfpa.org/Codes/CodesAndStandards.asp.

- 8 The Outdoor Air Calculator was developed for the Food Service Technology Center by Architectural Energy Corporation and funded by Pacific Gas & Electric Company. The software is free and available for download from the following web site: www.archenergy.com/oac.



An EDISON INTERNATIONALSM Company



Energy Design Resources provides information and design tools to architects, engineers, lighting designers, and building owners and developers. Our goal is to make it easier for designers to create energy efficient new nonresidential buildings in California. Energy Design Resources is funded by California utility customers and administered by Pacific Gas and Electric Company, San Diego Gas and Electric, Southern California Edison, and Southern California Gas Company under the auspices of the California Public Utilities Commission. To learn more about Energy Design Resources, please visit our Web site at www.energydesignresources.com.

This design brief was prepared for Energy Design Resources by Architectural Energy Corporation, Boulder, Colorado, and Fisher Nickel inc., San Ramon, California.