



Radiant Cooling

Summary

Unlike most cooling systems in California, which circulate cold air to maintain comfort, most radiant cooling systems circulate cool water through ceiling, wall, or floor panels. “Coolth” from that water is then absorbed by occupants and interior spaces according to the dynamics of thermal radiation. These radiant cooling systems, which are popular in Europe, are rarely found in California buildings, however. That’s bad news for building owners and occupants, because radiant cooling systems are more efficient, more comfortable, more attractive, and more healthful than systems that circulate air. Over their lifetimes, they are also less expensive to own and operate.

Given these advantages, radiant cooling is poised to make a big splash in California markets in all climate zones. Currently, there are two important barriers to its entry into these markets: a lack of familiarity with radiant cooling technology and lingering memories of moisture control problems experienced by a few pioneering systems installed decades ago. The latter barrier should be mitigated by recent advancements in sensor and control technology. The first barrier, local industry unfamiliarity, will probably diminish as information becomes more widely available about successful applications in Europe, North America, and California. Healthcare facilities, which especially benefit from the way radiant cooling systems separate comfort cooling from ventilation functions, may lead the way.

Radiant cooling systems are more efficient, more comfortable, more attractive, and more healthful than systems that circulate air.

CONTENTS

Introduction	2
Radiant System Economics	3
Design Considerations	4
Why Hasn’t Radiant Cooling Caught On in North America?	9
Recent Developments in California	12
Conclusion	14
Notes	16

A hydronic system can transport a given amount of cooling with less than 5 percent of the energy required to deliver cool air with fans.

Introduction

There are several good reasons designers should consider including radiant cooling systems in new buildings in any of California's climate zones. Commercial buildings primarily cooled by radiant means are more comfortable than buildings cooled by traditional HVAC systems. The first costs for radiant systems are comparable with those for traditional variable-air-volume (VAV) systems, but their lifetime energy savings over VAV systems are routinely 25 percent or even more.

With radiant systems, people are cooled by radiant heat transfer from their bodies to adjacent surfaces—ceilings, walls, or floors—whose temperatures are held a few degrees cooler than ambient. Space conditioning energy is usually moved from chillers or boilers to radiant panels or concrete slabs using water as a medium. This produces impressive savings, since water has roughly 3,500 times the energy transport capacity of air. Even accounting for the pressure drop involved in pumping water throughout a building, a hydronic system can transport a given amount of cooling with less than 5 percent of the energy required to deliver cool air with fans.

In most commercial buildings, both cooling and ventilation are accomplished by circulating large volumes of air throughout the conditioned space. This requires substantial fan power and large ducts, and it's a source of drafts and noise. With a radiant space conditioning system, the ventilating function is separate; the volume of air moved and the components to move it can be roughly five times smaller. Fan power is saved and ducts can be smaller.

In addition to substantially lowering energy and peak load costs for space conditioning and ventilation, radiant systems enjoy other advantages over VAV systems:

- Better indoor air quality (because ventilation air is not recirculated and there are no wet surface cooling coils, thereby reducing the likelihood of bacterial growth).
- Better user comfort, even at room temperatures closer to outside air temperatures, than is possible with convective space conditioning (because

radiant heat transfer is direct and draft-free; also, virtually no noise is associated with space conditioning).

- Better efficiency and possibly smaller sizes of chillers and boilers (because delivery temperatures are closer to room temperatures).
- Lower maintenance costs (because of inherent system simplicity—no space conditioning equipment is needed in outside walls, and a common central air system can serve both interior and perimeter zones).

Radiant System Economics

Figure 1 shows how radiant cooling systems achieve savings. The graphic breaks out the components of peak HVAC energy use in California office buildings for a conventional system and for a radiant cooling system that uses water as an energy transport medium. About 62.5 percent of the conventional system’s energy use consists of cooling load that the chiller must

The cooling load from lights decreases because the radiant system’s 100 percent outside air ventilation directly vents half of the lights’ heat to the outdoors.

Figure 1: Peak power demand for conventional and radiant cooling

The hydronic radiant cooling system reduces peak power demand by pumping chilled water to provide radiant cooling, rather than by blowing chilled air. Note that the cooling load from lights decreases because the radiant system’s 100 percent outside air ventilation directly vents half of the lights’ heat to the outdoors. In conventional buildings, most of that heat stays in the building with recirculating supply air.

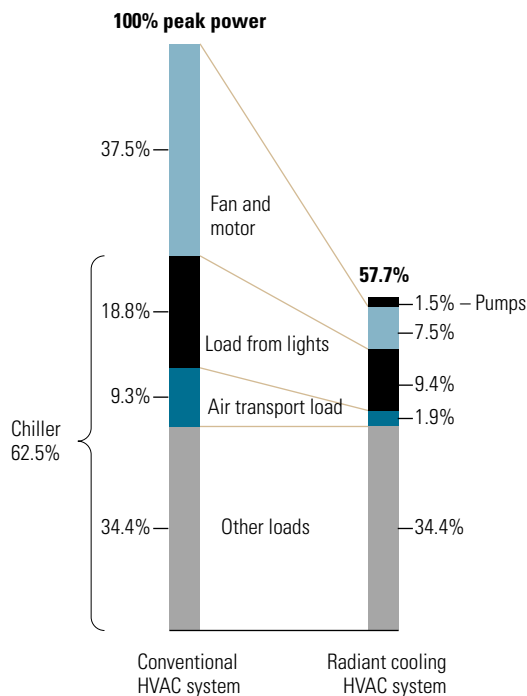

Source: LBNL

On average, the radiant cooling systems save 30 percent on overall energy for cooling and 27 percent on demand.

remove. Virtually all of the remaining power demand is used for air transport, and radiant cooling can eliminate most of that. As a consequence, in the example in the figure, energy savings is greater than 42 percent. In areas with high humidity during the cooling season, the savings are proportionally less.

Corina Stetiu of Lawrence Berkeley National Laboratory (LBNL) ran detailed simulations of the same prototypical office building located in nine U.S. cities, comparing the performance of radiant cooling systems with ventilation and conventional “all-air” VAV systems. In comparisons with VAV systems, she found that on average, the radiant cooling systems save 30 percent on overall energy for cooling and 27 percent on demand. Energy saved ranges from 17 percent in cold, moist areas to 42 percent in warmer, dry areas.¹ (The primary reason for lower savings in humid areas is that substantial dehumidification must be employed by both systems. Therefore, the ratio of energy savings to total energy is smaller.)

Of course, initial as well as energy costs are important in considering incorporating radiant cooling in a new building. According to Sean Timmons, a senior mechanical engineer with Arup and Partners in San Francisco, buildings with radiant cooling systems routinely show slightly lower first costs but substantially lower lifecycle costs than systems with four-pipe fan coil units.² Using current German prices, Franc Sodec, an engineer with Krantz-TKT in Aachen, Germany, ran simulations that show up to 20 percent savings in first costs by radiant cooling systems with ceiling panels versus standard VAV systems when the panels are designed to supply about 14 to 18 Btu per square foot of cooling.³ He also reports 40 to 55 percent savings in space requirements owing to less ducting.

Design Considerations

Radiant energy to condition a space can be delivered at temperatures only a few degrees different from the temperature of the conditioned space. For cooling, it is important to maintain the temperature of the outer surface of the tubing that carries cooling water above the dewpoint to avoid condensation. This constraint dictates that buildings be at least moderately well air-sealed and that in highly humid areas, ventilation air undergo some dehumidification. It also means that the cross-sectional areas of cool-

ing surfaces need to be big enough that adequate cooling energy can be delivered at small temperature differences. A happy consequence of relatively large areas of radiant surface is that the entire interior environment is uniformly pleasant.

In Europe, millions of square feet of commercial and institutional buildings that use radiant surfaces to supply space conditioning have been built in the last 25 years. According to Helmut Feustel, an international consultant in radiant cooling who headed LBNL's work in this area, hydronic radiant cooling has become the new standard in Germany.⁴ As long as the cooling surfaces are relatively extensive and supply temperatures are held above the dewpoint, radiant cooling can be achieved via several strategies, as illustrated by the descriptions that follow.

Mixed-Use Facility in Dusseldorf: Suspended Metal Panels with Tubes

Figure 2 shows a 237,000-square-foot combination office and retail sales space. A prestigious building, it houses in its top floors offices for the governor of the state of North Rhine–Westfalia. It uses suspended metal panels with metal tubes that carry water to accomplish both radiant heating

Hydronic radiant cooling has become the new standard in Germany.

Figure 2: Façade and interior office of a mixed-use building in Dusseldorf

This building has a glass wall in front of a structural façade that is also covered with glass. The combination wall system has an overall R-value of 6. Water to heat the building comes from a district heating system, which also supplies energy for absorption chillers used to produce cool water for the radiant cooling system and energy to condition ventilation air.



Source: Zent-Frenger GmbH

and cooling. During the heating season, room temperature is maintained at 68°F. Warm water is supplied to radiant panels at 95°F and returns at 88°F. During the cooling season, room temperature is maintained at 80°F by chilled water that is supplied at 61°F and returns at 66°F. During the summer, the panels supply about 27 Btu/h*ft² of cooling energy, which meets the entire cooling load. Should the temperature of supply water approach the dewpoint, humidity sensors actuate cutoff valves to ensure against condensation.

It is a characteristic of radiant systems that they can maintain good comfort with a wide spread of room temperatures from winter to summer. Because room temperatures are closer to ambient in both summer and winter, energy savings result in both seasons. In addition, delivering energy at small temperature differences from room air makes it possible for chillers (and heating systems) to operate more efficiently.

Bank in Bad Vilbel: Suspended Gypsum Board with Tubes

The 43,000-square-foot People's Bank in Bad Vilbel (**Figure 3**) is cooled by suspended gypsum board in which metal tubes that transport chilled water are embedded. Because they are suspended rather than being integrated into the ceiling, these "cooling sails" could also be used as a radiant cooling retrofit in existing buildings. This system maintains the bank building at 79°F during the summer with a supply temperature to the radiant panels of 59°F and a return of 63°F. The panels supply 24 Btu/h*ft², which meets the cooling load for the bank on the warmest day of summer. There is no mechanical ventilation.

Restaurant and Casino in Munich: Metal Ceiling Panels Cooled Convectively

This 4,300-square-foot restaurant uses an acoustic metal suspended-panel ceiling that is cooled by supply air from a traditional compressor-based chiller and fan (**Figure 4**, page 8). Its advantages over traditional VAV systems are that ductwork is less extensive (because the panels function as large diffusers) and space conditioning is supplied with virtually no drafts. Because about 60 percent of the heat transfer is via radiation, comfort is achieved at 71°F in winter and 79°F in the summer. According to the building owner, Siemens AG, the panel ceiling and all necessary ductwork cost

Because room temperatures are closer to ambient in both summer and winter, energy savings result in both seasons.

Figure 3: BVB Volksbank building in Bad Vilbel

The suspended gypsum board cooling sails cover most of the surface of the ceilings. About 200 people work in this building, and each office has individual climate controls. Chilled water is supplied via traditional compressors, which run quite efficiently since the supply water temperature is a relatively high 59°F. If the temperature of supply water approaches the dewpoint, the radiant cooling system's sensors shut off supply water to the panels.



Source: Zent-Frenger GmbH

about \$7 per square foot installed—about 20 percent less than other radiant systems and 10 percent less than ordinary VAV systems.

Office Building in Offenburg: Integrated Tubes in Concrete Slab

This 50,000-square-foot office building is radiantly cooled by circulating water in tubes embedded in the concrete slabs that constitute its floors and ceilings. During the summer, the enormous mass is supplied with 64°F water that returns at 68°F, keeping room temperature at 79°F. This temperature is quite comfortable because workers are literally surrounded by a radiantly cooled envelope. The relatively high supply temperature ensures that the dewpoint is not likely to be approached. The radiantly conditioned area produces 11 Btu/h*ft² of cooling energy, 100 percent of the total needed. (Figure 5, next page). A small amount of mechanical

Figure 4: Restaurant and casino building in Munich

The few ducts above the suspended radiant panels blow air across the panels instead of across people. This inexpensive radiant cooling and heating system can be employed as a retrofit as well as in new buildings. Also shown are a conventional and an infrared photo of a conference room. The dark ceiling is cooler (19°C) than the walls (21°C). Although energy savings are not as substantial as with water-based radiant systems, initial costs are lower and comfort is excellent. The system shown can meet cooling loads as high as 57 Btu/h*ft².



Source: Wilhelmi Werke AG

Figure 5: Office building in Offenburg

In the early stages of construction, tubing for the radiant cooling system is delivered to the site (left). Before the concrete floor is poured, workers will thread the tubing through the rebar and connect it to registers with supply and return circuits. In this project, the radiantly cooled portion of the poured concrete slabs has an incremental cost over the unconditioned portions of \$3.25 per square foot. The building, Burda Medienpark in Offenburg (right), houses offices and conference facilities.

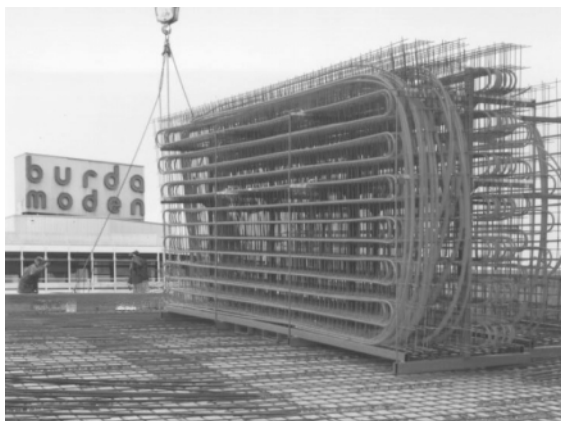

Source: Zent-Frenger GmbH

ventilation is supplied to the corridors and meeting spaces, but this ventilation air is not conditioned at all.

The concrete core radiant system used in this building is the least expensive cooling option of all (for both first and operating costs). Accordingly, it is becoming more popular than the systems installed in most German commercial buildings—suspended radiant panels and plastic capillary tubes buried in gypsum or similar board material installed in ceilings or walls. The three main types of radiant cooling systems are shown in **Figure 6**. **Table 1** compares their advantages and disadvantages.

Why Hasn't Radiant Cooling Caught On in North America?

“Good question,” says Mark Linde, a principal of a Canadian manufacturer of several lines of hydronic radiant panels that may be used for heating or

Figure 6: Principal types of hydronic radiant cooling systems

A core-cooled ceiling (left) is the cooling equivalent of a floor heating system. In this system, water is circulated through plastic tubes embedded in the core of a concrete ceiling. This layout allows the system to take advantage of the large storage capacity of the concrete and provides the opportunity to shift the building peak load away from the utility grid peak. Temperatures are very stable throughout the facility and users report excellent comfort, but there are usually no individual controls. The most widely used system is the panel system (center). It is usually built from aluminum panels, with metal tubes connected to the rear of the panel. An alternative is to build a “sandwich system,” in which the water flow paths are included between two aluminum panels. The use of a highly conductive material in the panel construction provides the basis for a fast response of the system to changes in room loads. Cooling grids made of capillary tubes placed close to each other (right) can be embedded in plaster or gypsum board or mounted on ceiling panels. This system provides an even surface temperature distribution. Due to the flexibility of the plastic tubes, cooling grids might be the best choice for retrofit applications.

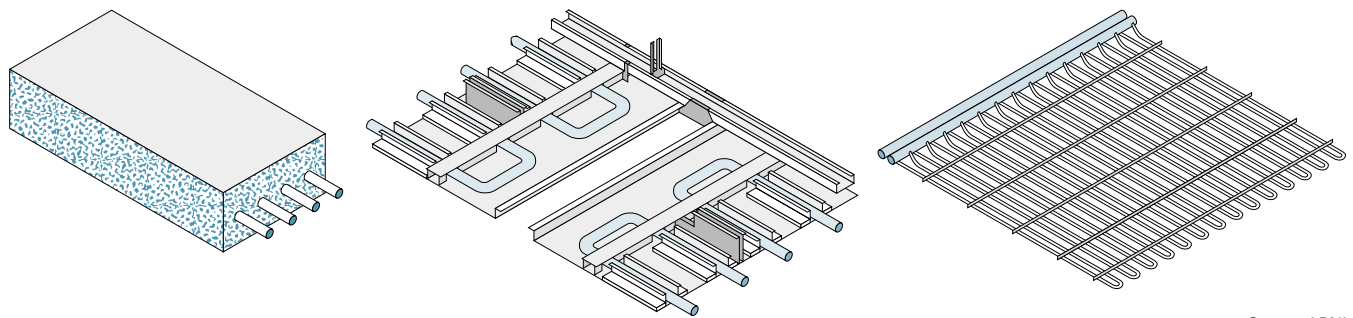

Source: LBNL

Table 1: Radiant cooling systems compared

The table below compares the three principal types of hydronic radiant cooling systems and the convective panel system.

System	Locus	Retrofit?	Initial cost	Efficiency	Peak shave?	Controls	Maintenance
Concrete core	Floors, ceilings	Not easily	Lowest	Excellent	Best	Large zones, slow	Lowest
Cool grids (tubes in gypsum)	Ceilings, walls	Yes, ceilings	Medium	Good	Good	Small zones, slow	Low
Metal panels (hydronic)	Ceilings, walls	Yes, ceilings	Medium	Good	Good	Small zones, fast	Low
Metal panels (convective)	Ceilings	Yes	Low	Fair	Poor	Large zones, fast	Medium

Modern sensors in combination with direct digital controls enable fast, accurate tracking and adjusting to optimize the cooling function while avoiding condensation problems.

cooling. When Linde makes presentations about radiant cooling, he finds that the technology is intriguing to engineers and academics. But when it comes to putting up new buildings, traditional VAV approaches usually hold sway, in part because the perception that radiant cooling systems have higher first costs still appears to be widespread. “I may be jaded,” Linde says, “but I believe that most buildings in North America are built with not enough thought about comfort or energy bills. Developers just want to build them at the lowest first cost possible.”⁵

Although Linde’s generalization seems overstated, it may contain a kernel of truth. In all fairness, there appear to be two main reasons why designers hesitate to embrace the technology. First, there’s the reluctance to be a pioneer. Promoters hope to surmount this barrier by showcasing a wide range of successfully radiantly conditioned buildings in Europe, including the German buildings illustrated in this report. For example, Hewlett Packard has a new facility in England that company officials like so well they plan to include its radiant cooling features in their next buildings in the U.S.

Second, there were moisture problems with some systems built several decades ago. To avoid condensation, radiant ceilings must be maintained several degrees warmer than the dewpoint. The trick is to be able to sense the dewpoint temperature with some precision and adjust incoming water temperature to achieve effective cooling while avoiding condensation.

“In the old days, we didn’t have the sensor or control technologies to solve this problem very well,” reports John Zapalik, a regional sales manager for an Illinois-based company that supplies radiant cooling equipment. “Also, some manufacturers weren’t able to achieve uniform thermal bonding between the water-bearing copper tubing and the metal ceilings. This resulted in lowered cooling efficiency and cold spots, which could cause condensation.”⁶ Currently, these technical problems appear to be satisfactorily resolved. Modern sensors in combination with direct digital controls (DDC) enable fast, accurate tracking and adjusting to optimize the cooling function while avoiding condensation problems. Further, manufacturers now use special fixtures in combination with reliable heat-conducting tapes or compounds to ensure good heat transfer between tubes and metal plates.

Of course, warm, moist air infiltrating into any air-conditioned building poses a problem that requires energy to solve it. The best approach in any climate is to build tight buildings and control air flow. The strategy employed with radiantly cooled buildings is to keep ventilation rates as low as possible consistent with maintaining good indoor air quality while relying on dehumidifying ventilation air to keep the dewpoint low.

This is the approach that Enermodal Engineering takes. The company designed Green on the Grand, a very energy-efficient 22,000-square-foot office building near Toronto (**Figure 7**). It uses radiant panels in the ceiling fed by a gas-fired combination boiler and absorption chiller. This system supplies warm or cold water depending on the season. The building is quite tight and uses a rotary-wheel energy-recovery ventilator system, which helps to lower the latent load and improve overall energy efficiency. Electricity use by the building is 60 percent less than for a similar building in the area built to ASHRAE 90.1 standards, and gas use for heating is half that of a 90.1 standard building. Gas use for cooling is higher than predicted by a computer model used in the design process owing to the poor overall coefficient of performance (COP) of the absorption chiller, which is oversized for the modest cooling load. Nonetheless, the

The strategy is to keep ventilation rates as low as possible consistent with maintaining good indoor air quality while relying on dehumidifying ventilation air to keep the dewpoint low.

Figure 7: “Green on the Grand” office building

The major tenant in this award-winning office building is Enermodal Engineering, the company that designed it. The pond in the foreground functions as a cooling tower, with return water being dripped on stones around its sides to enhance evaporative cooling. Makeup water is supplied by rainwater gathered from roof runoffs.



Source: Enermodal Engineering

Monitoring showed a cooling energy savings of 51 percent and a demand savings of 47 percent compared with a building that used a conventional rooftop unit without radiant cooling.

overall annual energy cost of the building is 28 percent less than a similar building built to 90.1 standards.⁷

Recent Developments in California

The Davis Energy Group has been involved in design work and monitoring of three recent projects aimed at saving cooling energy through “natural cooling” systems. These cool water—using evaporative coolers, cooling towers, or roof spray arrays operate at night when the wetbulb temperature allows more effective cooling. Water is stored in storage tanks and/or circulated through tubing embedded in the buildings’ concrete floors. For the three projects described here—a large convenience store, a five-story apartment building, and a manufacturing facility—energy and demand savings are substantial and paybacks are short.

Cooling for a California Mini-Mart

For a 3,620-square-foot mini-mart 20 miles west of Sacramento, the original plan called for cooling by a conventional 15-ton rooftop unit. Instead, the unit was downsized to 10 tons, and an evaporative cooler was added to precool condenser and ventilation air (**Figure 8**). At night, the unit cools water that circulates through tubing buried in sand immediately below the floor slab. Because much of the cooling load is supplied by the radiantly cooled slab, ducts were downsized, and a 2-horsepower ventilation fan motor was used in place of a 5-horsepower motor. Monitoring showed a cooling energy savings of 51 percent and a demand savings of 47 percent compared with a building that used a conventional rooftop unit without radiant cooling. The overall simple payback for the entire mini-mart system is less than a year. The system’s incremental cost of \$3,450—about a dollar per square foot—produces annual savings of \$838. With a downsizing credit from the local utility, Pacific Gas and Electric Co., its payback is 2.7 years.⁸

A Radiantly Cooled and Heated Historic Apartment Building

The five-story apartment structure at 580 Howard Street is a historic building in downtown San Francisco, where the coastal climate is characterized by lower wetbulb temperatures than in California’s Central Valley. The building has 30,000 square feet of radiantly cooled and heated floor space, a retrofit system achieved by embedding tubing in a light layer of concrete

Figure 8: Rooftop unit with precooler

Precooling condenser air with an evaporative system like this one can raise the efficiency of rooftop units by 25 percent in dry climates. This system also supplies evaporatively cooled water to the sub-slab tubing at night, which meets a substantial portion of the total cooling load. Pumping energy represents 3.8 percent of total energy use by the HVAC system.

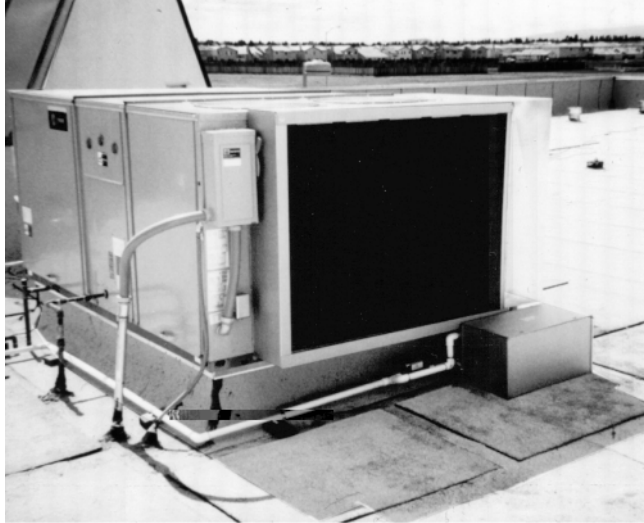

Source: Davis Energy Group

For a radiant cooling system retrofit of a San Francisco apartment building, the Davis Energy Group projects a demand savings of 84 percent and an electric energy savings of 61 percent over a conventional system.

immediately above the existing floors. Cooling is supplied by a cooling tower that has three stages of operation: spray only, low fan, and high fan. There is no compressor. A variable-speed pump supplies conditioning water to the building's many climate zones. The system was installed for \$140,000, considerably less than the \$500,000 quoted to install a conventional system of a compressor-based chiller and fan-coil units. In addition to these first-cost savings, the Davis Energy Group projects a demand savings of 84 percent and an electric energy savings of 61 percent over a conventional system.⁹

Night Sky Cooling for a Manufacturer

In 1998, a window manufacturing company built a 70,000-square-foot facility in Vacaville, 50 miles east of San Francisco. A conventional cooling solution would have required a 23-ton chiller. Instead, the building uses a night-operated spray array to cool water in a 10,000-gallon tank. Cooled water from the tank in turn is used to provide energy to a radiantly cooled slab and to five fan-coil units. Thus cooling in the building is both radiant and convective. A 10-ton chiller is used off-peak as needed, but the Night Sky roof spray cooling system, which cools water by evaporation and

night sky radiation, supplies 67 percent of the building's cooling needs. Energy savings are 70 percent and demand savings 87 percent over a conventional system. The incremental cost for the combination cooling system will be recouped in 2.5 years.¹⁰

Conclusion

“An adequately designed and operated radiant cooling system can function in a state-of-the-art office building at any U.S. location with low risk of condensation,” reports Corina Stetiu.¹¹ Systems can also be retrofitted in existing buildings, but cost-effectiveness evaporates when old buildings are leaky, especially in areas of high humidity. That nonetheless leaves a very large potential market for radiant systems.

There's strong evidence from simulation results, European experiences, and successful projects in two of California's climate zones that radiant cooling systems work well and are cost-effective. However, it seems unlikely that the technology will be fully embraced in North America until several good buildings are built in a range of climate zones and their performance is documented.

Healthcare facilities should be prime candidates because radiant space conditioning works well with single-pass ventilation. (Traditional HVAC systems that circulate air tend to circulate bacteria as well.) Major healthcare facilities like the Oak Park Hospital in Illinois have successfully used radiant cooling for many years, and a radiant cooling system is being installed in the Cook County Hospital in Chicago. Such prominent institutions as UCLA and the University of Michigan are investigating radiant cooling technology for possible inclusion in both new and retrofitted buildings. Consequently, the design professionals emerging from these schools may become more familiar with radiant space conditioning and thereby hasten the adoption of this practical technology.

FOR MORE INFORMATION

Chapter 6 of the ASHRAE *Handbook on HVAC Systems and Equipment* (2000) is dedicated to the design and performance of radiant heating and cooling systems.

American Society of Heating , Refrigerating, and
Air-Conditioning Engineers (ASHRAE)

1791 Tullie Circle NE

Atlanta, GA 30329

tel 404-636-8400 or 1-800-ASHRAE

fax 404-321-5478

web www.ashrae.org

Energy and Buildings, Volume 30, Number 2, published in June 1999, is a special issue on hydraulic radiant cooling of buildings. Guest-edited by Helmut Feustel, the issue includes 10 papers on the economics and design of radiant cooling systems in various climate zones around the world. Available from Elsevier Science, P.O. Box 945, New York, NY 10159, tel 212-633-3730, toll free 888-437-4686, fax 212-633-3680, e-mail usinfo-f@elsevier.com.

The Radiant Panel Association provides leadership to the radiant cooling and heating industry through comprehensive education while fostering the awareness of radiant comfort and innovative technology.

Radiant Panel Association

Lawrence Drake, Executive Director

1433 West 29th Street

Loveland, CO 80538

tel 800-660-7187, 970-613-0100

fax 970-613-0098

e-mail misc@rpa-info.com

web www.rpa-info.com

Notes

- 1 Corina Stetiu, "Energy and Peak Power Savings Potential of Radiant Cooling Systems in U.S. Commercial Buildings," *Energy and Buildings*, v. 30, no. 2 (1999).
- 2 Sean Timmons, personal communication (July 5, 2000), Senior Mechanical Engineer, Arup and Partners, 901 Market Street, Suite 260, San Francisco, CA 94103, tel 415-957-9445 ext 234, fax 415-957-9096, e-mail sean.timmons@arup.com.
- 3 Franc Sodec, "Economic Viability of Cooling Ceiling Systems," *Energy and Buildings*, v. 30, no. 2 (1999).
- 4 Helmut Feustel, personal communication (July 14, 2000), energy consultant, Lahnstrasse 48, D-35435 Wettenberg-Launsbach, Germany, tel 49 (0) 641/877 2012, Fax: 49 (0) 641/877 2137, e-mail hefeustel@tga-feustel.de, web www.tga-feustel.de.
- 5 Mark Linde, personal communication (June 29, 2000), Principal, Two Panel Systems Inc., 1201 4th Street, Nisku, Alberta, Canada T9E 7L3, tel 780-955-8757, fax 780-955-8696, e-mail Mark@twapanel.ca.
- 6 John Zapalik, personal communication (July 5, 2000), Midwest Regional Sales Manager, Invensys Building Systems, 15774 South LaGrange Road, Suite 119, Orland Park, IL 60462, tel 708-349-6636, fax 708-349-6646, e-mail Jzapalik@redec.com.
- 7 Stephen Carpenter and John Koklo, "Radiant Heating and Cooling, Displacement Ventilation with Heat Recovery and Storm Water Cooling: An Environmentally Responsible HVAC System," *ASHRAE Transactions*, v. 4, part 2 (1988). See also www.enermodal.com for a brief case study on the Green on the Grand building.

- 8 Richard Bourne and Marc Hoeschele, "Applying Natural Cooling to Slab Floors," ACEEE Summer Study on Energy Efficiency in Buildings (2000). American Council for an Energy-Efficient Economy, 1001 Connecticut Avenue NW, Suite 801, Washington, DC 20036, tel 202-429-0063, fax 202-429-0193, e-mail info@aceee.org, web www.aceee.org.
- 9 Richard Bourne and Marc Hoeschele [8].
- 10 Richard Bourne and Marc Hoeschele [8].
- 11 Corina Stetiu [1].



An EDISON INTERNATIONALSM Company

Energy Design Resources provides information and design tools to architects, engineers, lighting designers, and building owners and developers. Energy Design Resources is funded by California utility customers and administered by Pacific Gas and Electric Company, San Diego Gas and Electric, and Southern California Edison under the auspices of the California Public Utilities Commission. To learn more about Energy Design Resources, please visit our Web site at www.energydesignresources.com.

This design brief was prepared for Energy Design Resources by Financial Times Energy, Inc., Boulder, Colorado.